

A. Package Content

- Controller x 1, wall hanger x 1, warranty card x 1, user manual x 1, kit pack x 1
- Kit pack : screw x 4, screw anchors x 4, torx screw x 2, diode (1N4004) x 1, screwdriver x 1
- 8 pin cable x 1, 3 pin cable x 1, 2 pin cable x 1

B. Installation

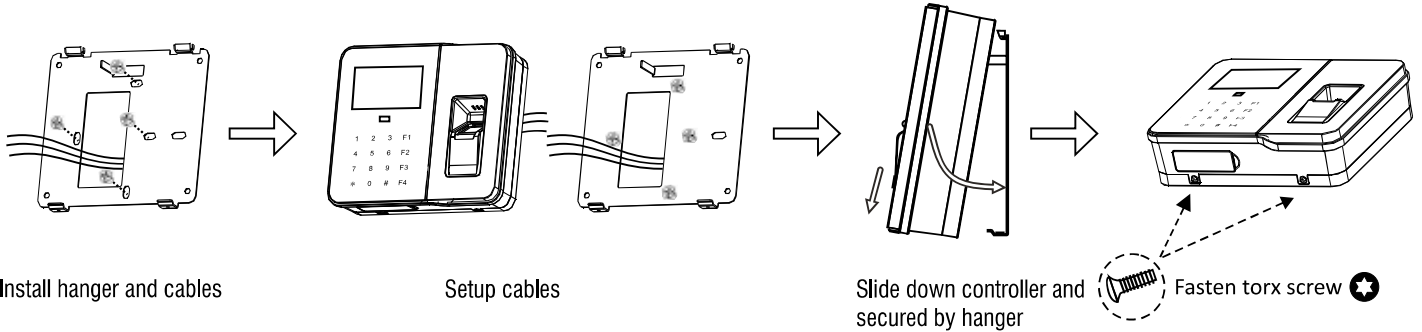

C. Specification

- Dimension : 160.2 x 140.2 x 46.7 mm
- Voltage range : 9 ~ 24 VDC
- Current : Max 500mA (Recommended use 1A)
- Wiegand range : Max 80M
- TCP/IP range : Max 100M (add hub to extend)

D. Webserver Introduction

- Default IP Address : 192.168.0.66
- Default WEB Account : admin
- Default WEB Password : admin

E. Enter Administrator Mode Guide :

- Press F1 + F1 → enter default password 111111 → press # (Yes = # ; No = *)
- Add user
Advance setup → user → add user single / continuous → enter UID → register card if any → register fingerprint if any → register password if any
- Delete user
Advance setup → user → delete user → present card or enter UID → press #
- Setup IP address
Advance setup → setting → IP config → enter IP / subnet / gateway
- Setup date&time
Advance setup → setting → date & time → enter time HH/MM/SS (24hr) → press # → enter date YY/MM/DD (ex : 2010/6/30) = 100630 → press #

F. Controller Hanger Dimension

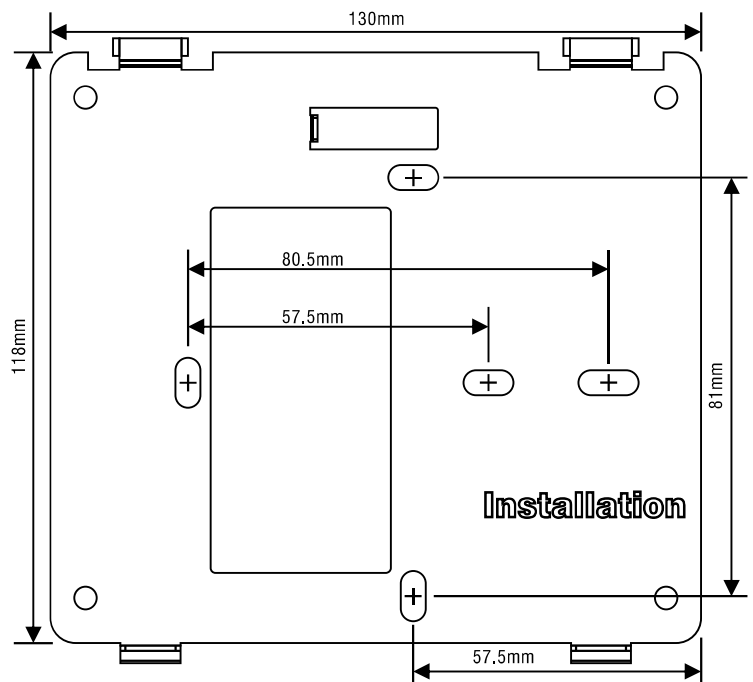

G. Application structure

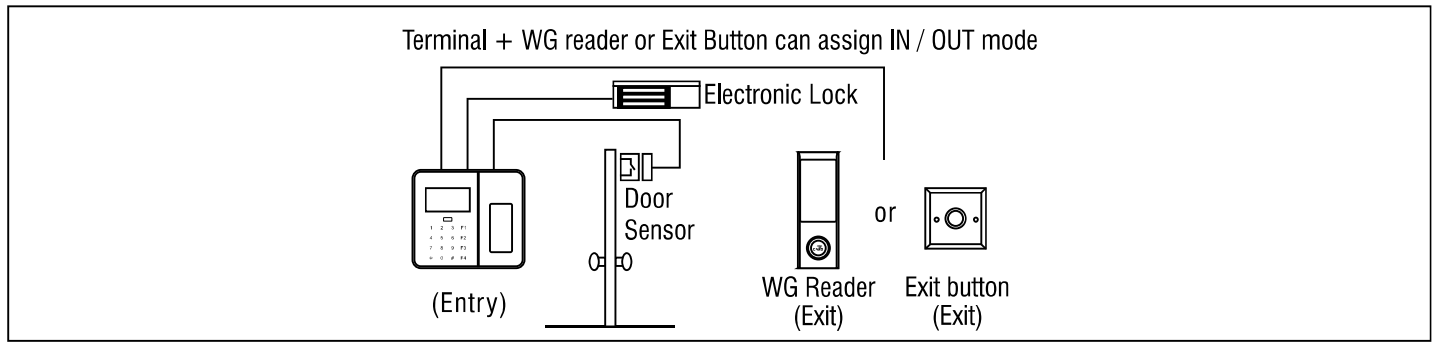

H. Controller Backside Introduction

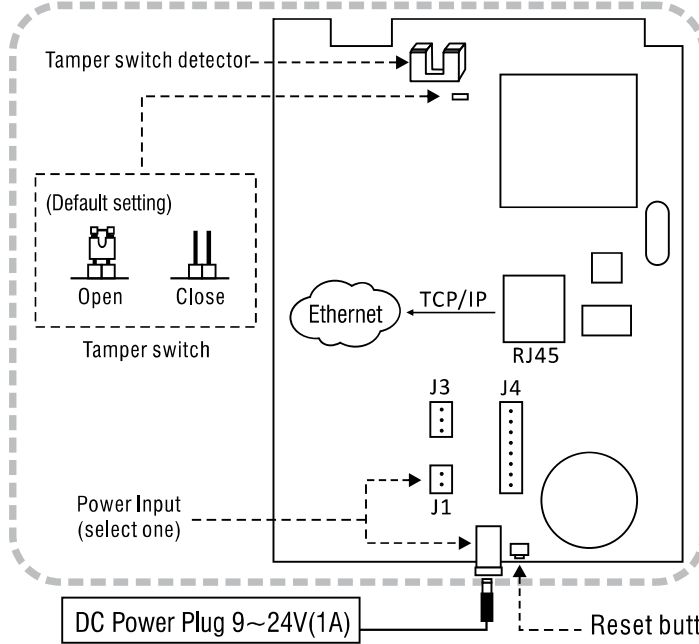

I. Cable Color Description

3 pin(J3)

COM	BLACK	Door Relay
NO	BROWN	
NC	GRAY	

2 pin(J1)

VIN	RED	DC Power Input 9~24VDC 1A
GND	BLACK	

8 pin(J4)

DOOR	YELLOW BLACK	Exit Button
SENS	WHITE BLACK	Door Sensor
FIRE	GREEN BLACK	Fire Alarm Input
OD0	RED WHITE	WG Output
OD1	BLACK WHITE	
GND	BLACK	GND
WID0	ORANGE	WG Input
WID1	PINK BLACK	

Electronic lock and door relay connection

• Electronic Fail Safe mode

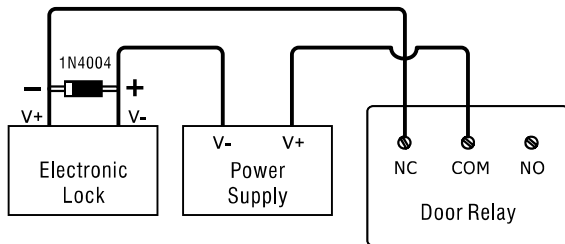

• Electronic Fail Secure mode

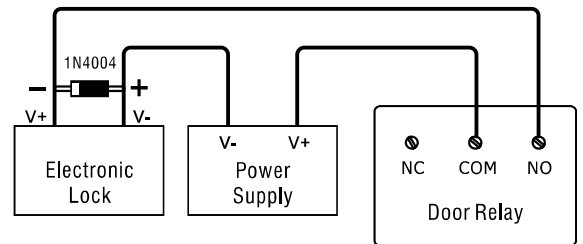

J. Cable Diagram

